

Philosophical theory of the fourth dimension of the unified space, the frequency or inertiality and of the phenomenon of inertial induction

Abstract

By means of 6 hypothesis, a new proposal of how we can see our surrounding space is explained. It intends and they explain 2 basic ideas. First a widen to the Cartesian analytic geometry, due to the manifestation of a fourth dimension; the one that one manifests, as the ownership to a certain phenomenon, reflecting the tendency of the function that represents it. In second place, it thinks the universality of the induction is proposed; one of the characteristics of the frequency, proposal as fourth dimension of the Cartesian system. Alter some evaluations have been made, meditating with the generating magneto - electro - dynamic and using a tensor of the same name; it thinks that the non alone induction happens for the electromagnetic phenomenon, because it is the most universal form of transmission of energy, for any type of interactions and it is denominated, inertial induction. In this phenomenon, the electric and magnetic manifestation of the tensor magneto - electro - dynamic, also participate, the vector cross product of these last ones, the mass's manifestation. If some variations of one of the elements of the tensor occur, they impact on the other ones.

1) Introduction

The present text intends a new vision of the Cartesian analytic geometry, because to the three dimensions of this (high, long, depth, to use common terms) it is added the tendency of the point, a fourth dimension with some other implications.

It also intends, the idea, of the universality of the induction phenomenon, as **inertial induction, the universal form of transmission of the energy, independently of the interaction type, that which makes that the unification of all the types of forces is seen**; phenomenon in the one that no longer alone the electric manifestations and the magnetic ones intervene, but their vector cross product, a mass's manifestation, then: The inertial induction, is a generalization of the induction in the event of the interactions electro - magnetic, being included the fact that, no longer alone the magnetic field generates the electrician, because it also happens the corresponding incidence in the mass's manifestation and vice versa; variations of the mass's manifestation induce changes to the electro - magnetic manifestations. It stays the position of Maxwell, that this interactions happen in the space, independently of the manifestations of the space that it can show.

2) Firsts Hypothesis

1. In a physical phenomenon's space, four dimensions exist: Long (x), high (and), depth (z) and frequency or inertiality (w).

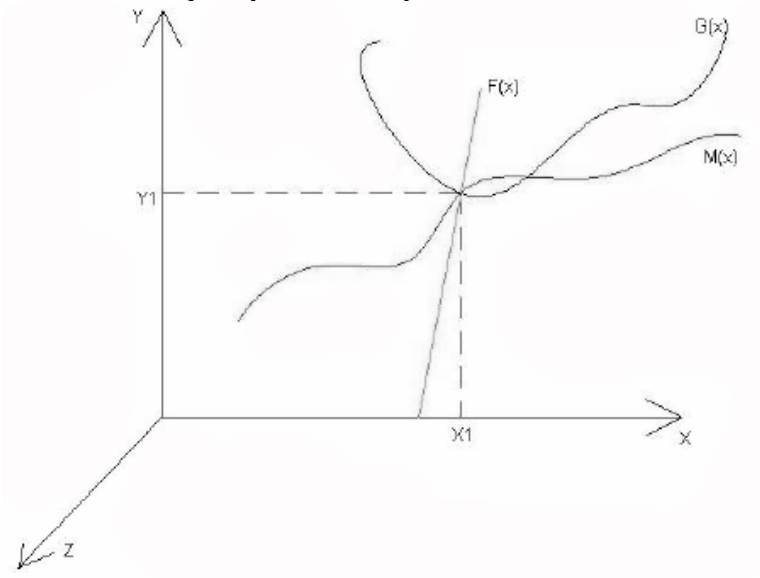

Figures 1: In the space of 3 dimensions, the point $P(X_1, Y_1, 0)$ that like one observes, it is the interception between $F(X)$, $G(X)$ and $M(X)$. In a space of 4 dimensions, this interception point would be $P_1(X, Y, Z, W_f)$, $P_2(X, Y, Z, W_g)$ and $P_3(X, Y, Z, W_m)$; that is to say, they would be 3 different points, since W , when representing the tendency or the following value", it is different for $F[W_f]$, $G[W_g]$ and $M[W_m]$. To watch that so much F , G like M , they can be represented as a group of three parametric equations each one, of the coordinated X , Y and Z . This parameter is the frequency, this parametric equations are obtained by means of a variational calculus

2. The dimension (w), has variational character. That which doesn't mean another thing that: The tendency to follow the minimum (stationary value).
3. In the points of the space 4-dimensional, a tensor one exists magneto-electro-dynamic, characterized by:
 - a. The angle between the electric manifestation and the magnetic manifestation, is (w), the fourth dimension (frequency or inertiality).
 - b. The vector cross product among the magnetic and electric manifestation, generates a vector of mass's manifestations or dynamic vector.
 - c. The angle between the magnetic and electric manifestations (frequency or inertialidad), is regulator of the interaction type.
4. The inertiality is not more than a manifestation of the induction, property of all energy transmission, of the any type of energy.

3) Imaginary experiments

It is known that a generating magneto - electro - dynamic consists in (to see figure 2) [1]:

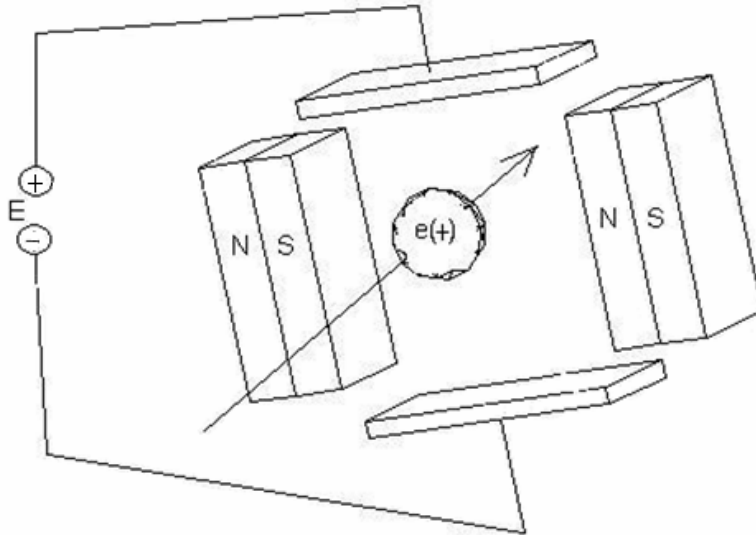

Figures 2: A flow of charged particles that it cross the magnetic field formed by the poles north (N) and south (S) they generate a current for the electric field E, like leave in the figure, perpendicular to the lines of imaginary forces between both imams

Phenomena in the generating magneto - electro - dynamic (it is given this name intentionally, although this device is known as, generating *magnetohidrodinamic*).

- I. If one has the magnetic field N - S and the charge $e(+, -)$ to the one that has been given an impulse, the electric field E will be obtained then. [1]
- II. It is also known that if one has the magnetic fields N - S and the electric field E, to the particles charge $e(+, -)$ they would be transmitted an impulse if they are inside both fields.
- III. It is being supposed that:
 - a. If one has N - S and the electric field E, then a particle without charge that it passes fields between both, according to the direction of the impulse, it will acquire a charge $e(+, -)$. it brings it as consequence, a braked or resistance to the movement for reinducción; being explained with it, the famous concept of inertial mass and gravitational mass, developed by A. Einstein in their General Theory of the Relativity, explaining Galileo Galilei's famous experiment on fallen free of the bodies in the vacuum and reason why according to Eintein, any body can overcome the speed of the light. [2]
 - b. The same as in the previous parenthesis (a.) the magnetic fields N - S and the electrician fields E, but, this time if there is a charge, to which is made cross through both, then with an impulse contrary to the logic you can achieve a charge change. Let us say if one makes this with plasm of Deuterio or Titrio the isotopes of hydrogen, its charges can be changed and to make them already collide without the force of repulsion corresponding to their normal states; it could be the solution for the yearned nuclear coalition controlled for energy ends.

- c. If one has the same as in the previous parenthesis (b.) the magnetic fields N - S and the electrician E, but, similar with a charge, but this time with a favorable impulse, mass can be induced to this particle.

4) Real experiments

It takes a cylindrical plastic tube and they are placed in their exterior to all the long one, two permanent, placed imams one in front of another over the imaginary line corresponding to the diameter of the cylinder, one points to the center of the cylinder with the north pole and the other one with the south pole; the imams have a cylindrical form. Perpendicular to the imaginary direct line of the diameter of the cylinder that it occupies the poles north and south of the imams, 2 electrodes are placed in each end. This time, the charged particles is contributed by an electrolyte or water with common salt.

When the electrolyte with rectilinear and uniform movement pass through the interior of the cylinder an electric field E it is generated, between the electrodes. It is a syntony of the induction phenomenon, with a system of inertial reference.

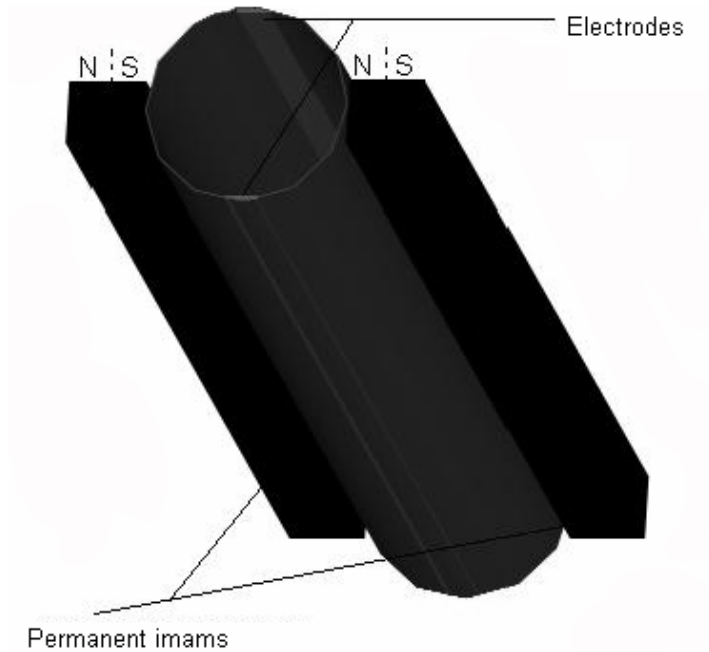

Figure 3: Device outline that could make of generating magnetohydrodynamic, to low temperatures, using an electrolyte as charge in movement

5) Energy. Energy's manifestations. (Mental exercise)

The energy is the same, alone that one manifests in different ways, for example:

- I. When apply thermal energy, to a substance, as it is the type, to a given temperature the molecules separate for example, of the liquid state to the gassy one (according to the temperature and other thermodynamic variables), in state of vapor they are inert to the graveness, if they are given more energy they are removed electrons and other particles. The thermal energy affects them, not only internal forces of attraction repulsion of atoms and molecules, also the graveness.

- II. The points 4-dimensional of the space is transmitters of the energy; the nature of that energy it is regulated by W .
- III. The energy (It is shown in different ways according to the type of interactions) there are variations of the tensor magneto - electro - dynamic.

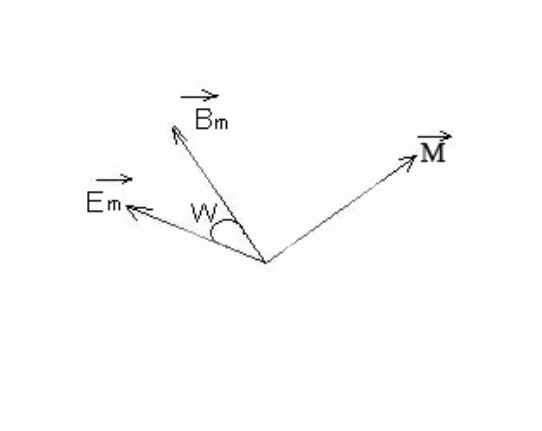

Figures 4. If for an interaction it is impacted more by specific combinations in one or more than one, of the features of the tensor magneto - electro - dynamic; it makes it the difference

- IV. The inertia is not patrimony or manifestation of the phenomenon of mass's movements, it is manifested in all the processes of status's changes and in the changes of types of interactions.
- V. The variations of the angle between \vec{B}_m and \vec{E}_m (the magnetic and electric manifestations), they can be equivalent to variations of each one of these fields (B and E) because these they are you don't standardize. Those variations of the non uniformity of the electric and magnetic fields can respond to functions; that given the inertial nature of the angle among this fields (the frequency), it responds to the result of a calculus of variations.[3]

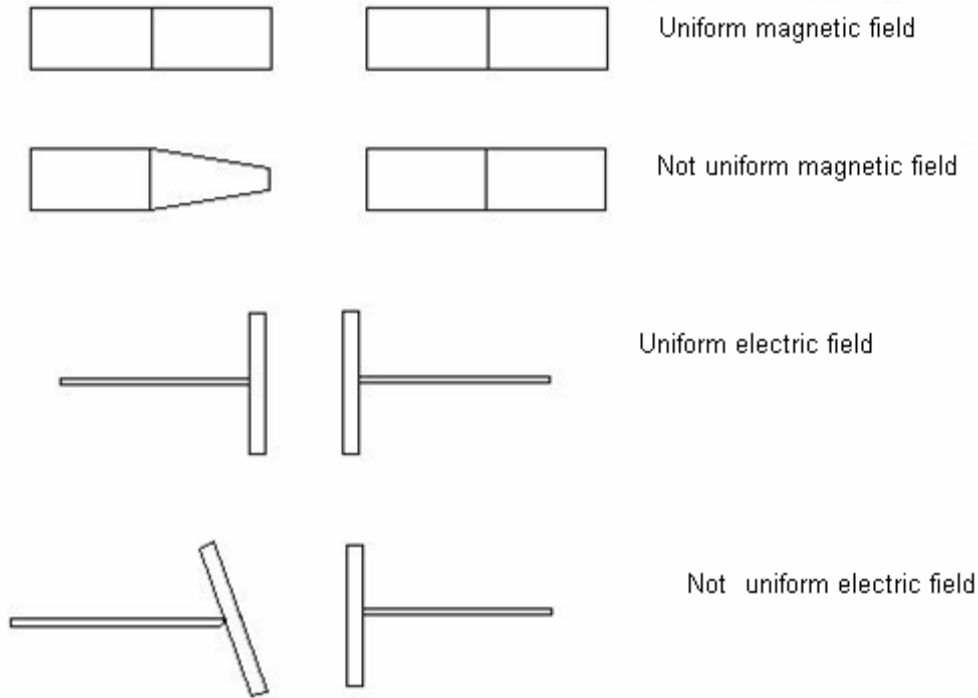

Figures 5: In this outline some of the possible forms of variations of the electric and magnetic fields of the generating magneto - electro - dynamic is explained; as well as these variations could be equivalent to changes in the angle of reference of both fields in the generating magneto - electro - dynamic, the one which in turn can be expressed by a function that is derived of a variational calculus

6) The fourth dimension is everywhere

The following figure, represents a volume (V) irregular, a solid of 2 tonalities, to which is applying heat.

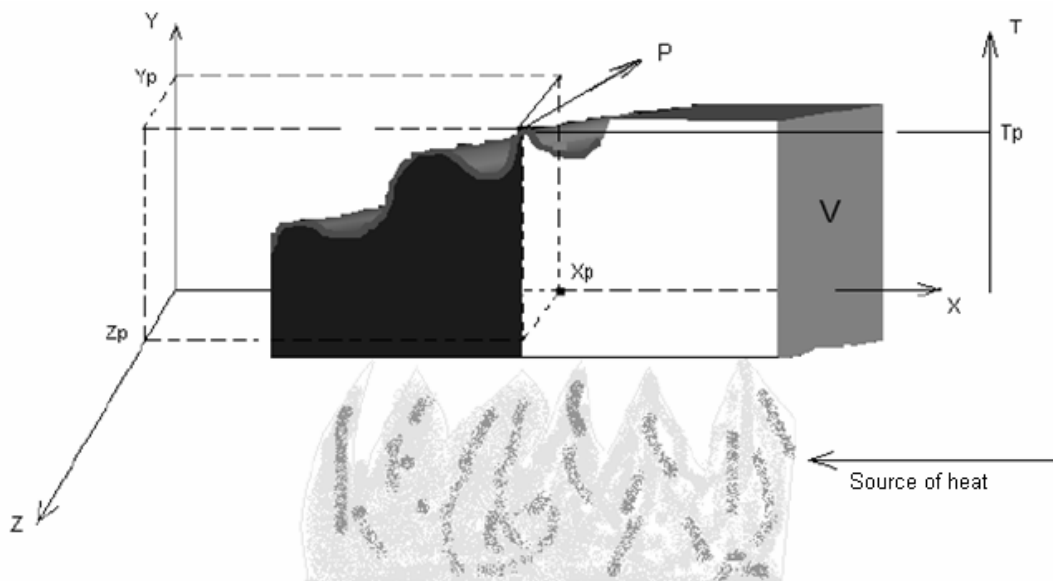

Figures 6: Solid body to whose volume is given heat. The case of the point P is stood out

In the figure 6, the line in wavy form, one of the irregular edges of the volume represents V . For this case the point P , it becomes the points $P1(X1,Y1,Z1,W1)$, where $W1$ responds to the function $F(W)$, representing the trajectory of the wavy line of the irregular edge, like one observes in the figure 6; $P2(X2,Y2,Z2,W2)$, where $W2$ respond to the function $\tau(W)$, representing the distribution of the temperature that varies for this case according to the height to that it is measured in the volume (it coincides with the coordinate Y); $P3(X3,Y3,Z3,W3)$, where $W3$ respond to the function $C(W)$, representing the distribution of tones in the volume.

$$X1 = X2 = X3; \quad Y1 = Y2 = Y3; \quad Z1 = Z2 = Z3; \quad (1)$$

$$W1 = 0; \quad W2 = T_p; \quad W3 = A \quad (A = \text{Oscuro y } B = \text{Claro}) \quad (2)$$

In this case $W1 = 0$, since it is $F(W)$, static function; but, if in the point P , happened an interaction, for example a crash, another would be the value of $W1$. Here, the syntony phenomenon is allowed to be seen, because the crash is syntonized with the point $P1$, but as it is the phenomenon, it would also be syntonized or with $P2$ or with $P3$.

7) Forms that it takes the space and the energy

Meditating: The gravitation law outlines that the attraction of 2 bodies with mass is inversely proportional to the square of the radial distance among these and directly proportional to the product of its masses. However, when heating a fluid, if it is liquid, a moment arrives in that the molecules of this in the call evaporation process, begin to stop to syntonize with the gravitational interaction, the same as when it warms a globe and east rises or some thermodynamic qualities as in the dirigibles that make that this it floats. It is like in the interactions among 2 different charges that are attracted and suddenly one of two changes their charge for some cause and begin to be repelled. The example of the evaporation and the globes, they are given by the form of energy transmission.

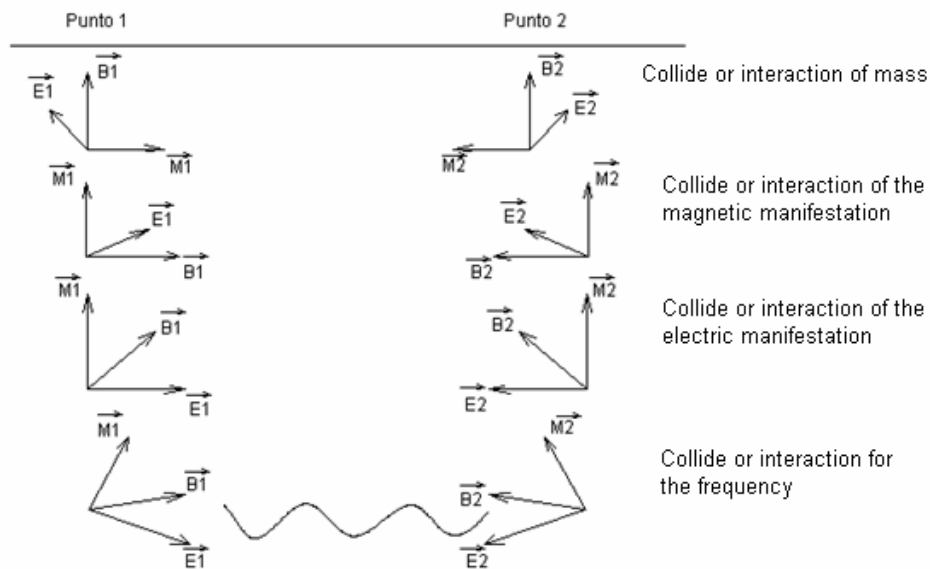

Figures 7: Outlines in possible ways of interactions among types of energy

During the " crash " or energy transmission there happen variations of the other 2 vectors and in the case of the frequency, of the three vectors of the tensor one, all regulated by the laws of calculation of the vector cross product and being the frequency the factor that fixes the minimum (stationary value).

8) Interaction among 2 points

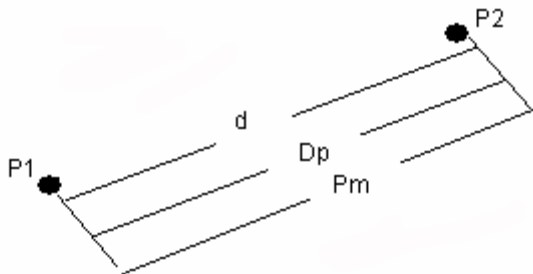

Figures 8: Outlines of the interactions between two points of the space with fourth dimension

- It is known that it enters P1 and P2 a distance it exists d (\mathbf{M}).
- Therefore a potential difference $Dp = |Em1| - |Em2|$.
- And a magnetic polarization $Pm = |Bm1| - |Bm2|$.
- A $\Delta W = W1 - W2$.

For an interaction of a type ΔW doesn't vary, that is to say, if it is gravitational, electro - magnetic, strong or weak.

Between P1 and P2 there is a W that determines an inductivity (a capacity, of an energy transmission), function that it carries out the magnetic and electric manifestations, that which connects to a point with other (P1 with P2), then the different variations of the states of P1 regarding P2 or vice versa is manifested (ΔW , $\Delta|Bm|$, $\Delta|Em|$, $\Delta|M|$).

9) About the inertial induction and the form of transmission of the energy

The process of transmission of the energy always happens for continuous induction, the electric manifestation, generates to the magnetic manifestation, and so successively; but that combination of \mathbf{Bm} and \mathbf{Em} , they generate a vector resulted of the vector cross product of them and it represents the mass's manifestation \mathbf{M} .

For all mentioned before, it is evident an amplification to the position of Maxwell in their theory of the electromagnetic field:

The magnetic manifestation generates to the electric manifestation and vice - versa, but the mass's manifestation is also generated and between they three, they are generated mutually, independently of the manifestations of the space that it is manifested (metal conductor, etc).

- When an airplane flies to high speed, the resistance of the air increases to a very high proportion, with regard to it one travels to smaller speeds. It is due to a reinduction to high speeds (already what induces him the vector of the mass manifestation for the high speed to the tensor magneto - electro - dynamic, it is perceptible).
- If a body moves near to light's speed, therefore, the relativity's phenomenon occurs, increase of the mass, variation of the longitude and contraction of the time, everything it, according to the special relativity of Einstein. However, the explanation for increase of the mass, is based on a reinduction.[4, 5]

- Let us say, using as example the elaboration of the ceramic ones; they mix several components, the high temperatures make the conversion to the final product. The energy applied an inductive impulse until the final material becomes to the new inertial state.
- The reinduction is related with the number III of the phenomenon of the generating magneto - electro - dynamic (exposed here in section 3). That is to say like one depends on the other 2 vectors and the other ones 2 they depend on the first one, it means that when showing an important influence on one of them, it acts on the other ones, it should be remembered that the electromagnetic induction, the only acquaintance up to now, when showing in a conductive material, it generates a current whose field magnetic variable, is opposed to the cause that produces it.

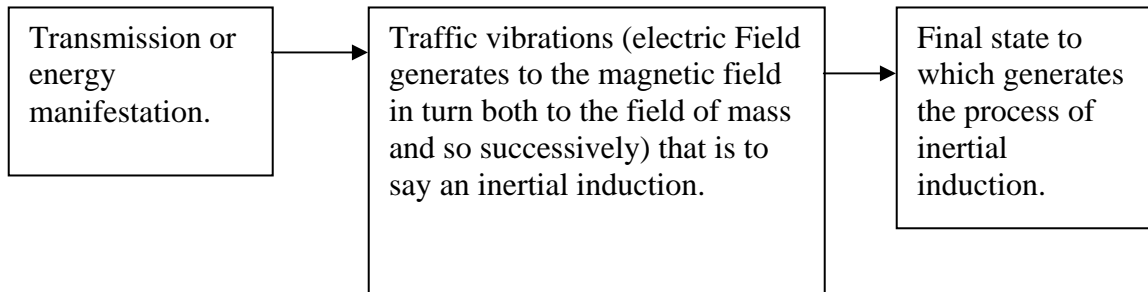

Figures 9: As the inertial induction it works

Hypothesis about the universal form of energy's transmission.

5. When we put the hand to push an object, that form of transmission of the energy, doesn't differ in anything respect to the sun transmits us the heat of its rays, the Earth attracts to the Moon and all the other energy interactions. The hand that pushes to a body, acts on this last one through its mass's vector, it is there where the inertia begins; the vector \mathbf{M} , variations of $\mathbf{E_m}$ and $\mathbf{B_m}$ that don't always have to show as same the electromagnetic induction induces it is known in presence of charges (for that reason it is said that it is a process of inertial induction). it is then that under the new conditions $\mathbf{E_m}$ and $\mathbf{B_m}$, they induce \mathbf{M} and so successively, for that reason the body moves. If it is to transmit heat; the variation of $\mathbf{B_m}$ and $\mathbf{E_m}$ impact on the object, it is known appraisable an electromagnetic wave of infrared, same frequency, $\mathbf{B_m}$ and $\mathbf{E_m}$ induce \mathbf{M} and then \mathbf{M} induces $\mathbf{B_m}$ and $\mathbf{E_m}$ in a successive way causing the energy transmission. It happens this way for all type of energy interaction.

10) Systems of inertial reference. General proposal of the mathematical calculation

The syntony of the inertial reference, is only the relationship between the vector's radius $\mathbf{V_p}$ from the origin of coordinate of the given system, with the tensor magneto - electro - dynamic of the phenomenon in question. It happens this way for every type of energy interaction.

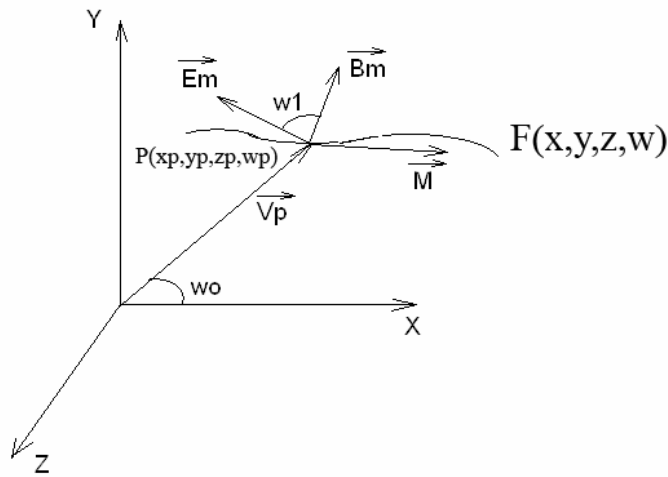

Figures 10: Scheme of the syntony of a system of inertial reference with a phenomenon

For the above-mentioned, the following hypothesis:

6. As for systems of inertial reference; the syntony happens for a phenomenon type or interaction when the angles are equaled (frequencies), of the vector's radius from the origin of the system of coordinated to the function that describes the phenomenon (w_0), to the angle between the magnetic manifestation and the electric manifestation w_1 ($w_0 = w_1$), of each point of the equation that describes to the phenomenon.

It is also added that energy manifestations can exist with almost null **M** for what **Bm** and **Em** prevail, the most common is the heat whose generates an opposition to **M**. The other case, is when one manifests **M** and **Bm** and **Em** are almost null, as the graveness whose frequency is very low and that it can be in opposed of the heat and other manifestations of almost null **M**. For example: A molecule of water, in liquid state shares the space of a container, in which one manifests, attracted by the force of graveness. To the heated being the liquid, that molecule, lost its referential state regarding the graveness and the attraction of the earth influences less and less in its state of vapor. The heat seems frequencies to be, in values that they influence on the vector **M**.

Get you the attention to the fact of being **M**, a manifestation of the movement that happens in X, Y and Z, influenced by W. [6, 7, 8]

A possible mathematical equations, it would be a combination of the equations of Maxwell, with what is derived of the position of the inertial reference in the postulate 6, taking to W like parameter would be solved the parametric functions of X lastly, Y and Z, by means of a variational calculus (to not forget that W, is the dimension of the minimum (stationary value)). With all those elements it is paid to a system of equations given by the position of the vector cross product $\mathbf{Bm} * \mathbf{Em} = \mathbf{M}$ in form of the determinant:

$$\mathbf{Bm} = (xb - xp)i + (yb - yp)j + (zb - zp)k \quad (3)$$

$$\mathbf{Em} = (xe - xp)i + (ye - yp)j + (ze - zp)k \quad (4)$$

$$\mathbf{M} = (xm - xp)i + (ym - yp)j + (zm - zp)k \quad (5)$$

That is to say, the three vectors starting from the point P. For it the xp values, yp and zp, they will be given by the variational calculus of F by the functional position of three, in function of W like parameter that will give us each one of the xp(w), yp(w) and zp(w).

The equations system, according to the vector cross product in form of the determinant, it can use about this:

$$(ye - yp(w)) (zb - zp(w)) - (yb - yp(w)) (ze - zp(w)) = (xm - xp(w)) \quad (6)$$

$$(xe - xp(w)) (zb - zp(w)) - (xb - xp(w)) (ze - zp(w)) = (ym - yp(w)) \quad (7)$$

$$(xe - xp(w)) (yb - yp(w)) - (xb - xp(w)) (ye - yp(w)) = (zm - zp(w)) \quad (8)$$

If was important to keep in mind the problem according to the system of inertial reference, it should be included in the calculations after certain xp(w), yp(w) and zp(w); xb(w), yb(w) and zb(w), the xe(w values), ye(w) and ze(w) and of xb(w), yb(w) and zb(w).

Being more general the system of equations:

$$(ye(w) - yp(w)) (zb(w) - zp(w)) - (yb(w) - yp(w)) (ze(w) - zp(w)) = (xm - xp(w)) \quad (9)$$

$$(xe(w) - xp(w)) (zb(w) - zp(w)) - (xb(w) - xp(w)) (ze(w) - zp(w)) = (ym - yp(w)) \quad (10)$$

$$(xe(w) - xp(w)) (yb(w) - yp(w)) - (xb(w) - xp(w)) (ye(w) - yp(w)) = (zm - zp(w)) \quad (11)$$

11) Conclusions

The proposals given in this work, represent a resumed of the up to now reached by the science about the cosmological vision of the world. Continuation of an eternal road that continues still until the infinite thing, for which Galileo has trafficked, Newton, Maxwell, Einstein and many others. Louis-Victor of Broglie [9] in their moment he dared to outline their hypothesis on the properties wave-particle duality. It has been that; you generalized the induction concept like universal form of transmission of the energy, enlarging the laws of Maxwell and the hypotheses of Broglie, as Einstein the concept of relativity of Galileo generalized and the equivalence between the graveness and the acceleration of the bodies, as well as it was based on the equations of Maxwell. The generalizations of concepts managed until each moment, it has allowed to advance in the search of a theory of the unified field. [2, 4, 5, 7, 8]

These hypotheses have a character for the most part qualitative, this does not depend on the mathematical positions, the metric ones and the definitive equations will be the continuation; likewise, with the confirmation of the experiments proposed with the generating magneto - electro – dynamic.[1]

References

- [1] Yavoriski B M y Detlaf A.A. 1988 *Prontuario de Fisica* (ISBN 5-03-000584-6 Mir Moscow) p 283.
- [2] Haliday D, Resnick R., Krane K.S. 2003 *Fisica Volumen I Tomo 2* (Felix Varela Havana) p 404.
- [3] Elsgoltz L 1983 *Ecuaciones Diferenciales y Calculo Variational (Tercera Edicion, Mir Moscow)* p 324.
- [4] Yavoriski B M y Detlaf A.A. 1988 *Prontuario de Fisica* (ISBN 5-03-000584-6 Mir Moscow) p 81.
- [5] Haliday D, Resnick R, Krane K.S. 2003 *Fisica Volumen I Tomo 2* (Felix Varela Havana) p 519.
- [6] Goldfain I A 1968 *Elementos de Calculo Vectorial* (Ciencia y Tecnica CT Havana) p 64.
- [7] Yavoriski B M y Detlaf A.A. 1988 *Prontuario de Fisica* (ISBN 5-03-000584-6 Mir Moscow) p 346.
- [8] Saveliev I V 1984 *Curso de Fisica General Tomo 2* (Mir Moscow) p 211.
- [9] Goldin L L, Novikova G I 1990 *Introduccion a la Fisica Cuantica* (ISBN 5-02-013853-3 Mir Moscow) p 20.